

FORESTRY CRANE

G4200X



COSTA



Diagrama de carga



**CARACTERÍSTICAS
TÉCNICAS**

		G4200	G4200X
Load capacity	Ton.m	3.0	
Reach	m	7,0	8,7
Boom extension	mm	1,7	3,4
Slewing torque	kN.m	21.8	
Slewing angle	°(degrees)	400	
Height (slewing carter to column articulation)	mm	1710	
Width in tranport position	mm	1246	
Weight (without grapple, rotor or folding legs)	kg	1163	1224
Recomended Pump	Work pressure Oil flow Required power	bar l/min kW	220 110 24-33
Recomended equipment			
Rotor capacity	Ton	6.0	
Rotation angle		continuo	
Rotation torque	kN.m	1.9	
Weight	kg	43	
Grapple		COSTA G560	
Area	m2	0.27	
Weight	kg	140	

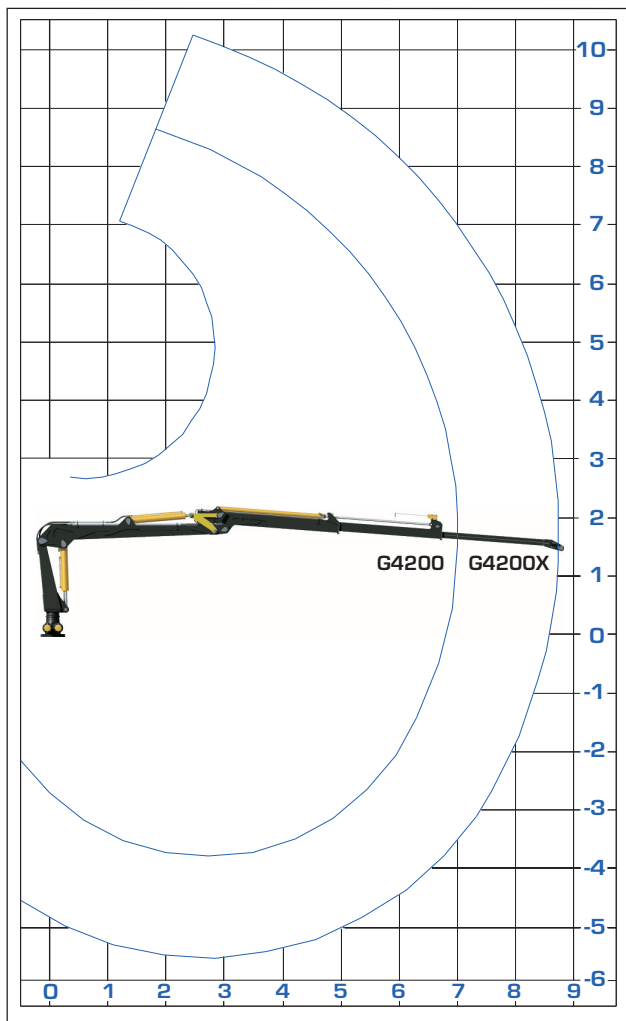
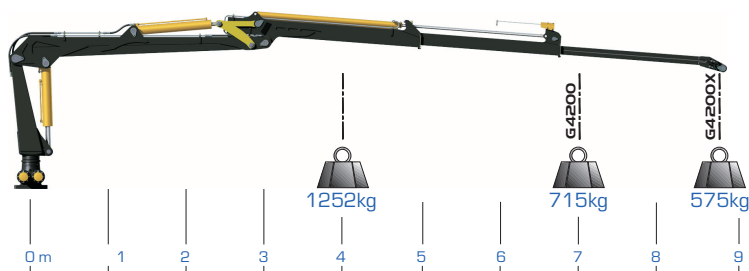
Afonso O. Costa - Fábrica de Máquinas Agrícolas e Florestais, Lda

R. Poeta Cavador, Moita
3780 - 476 Anadia

Tel. (+351) 231 510120
Fax (+351) 231 510125

www.aocosta.pt
geral@aocosta.pt



COSTA