

FORESTRY CRANE

G3000X

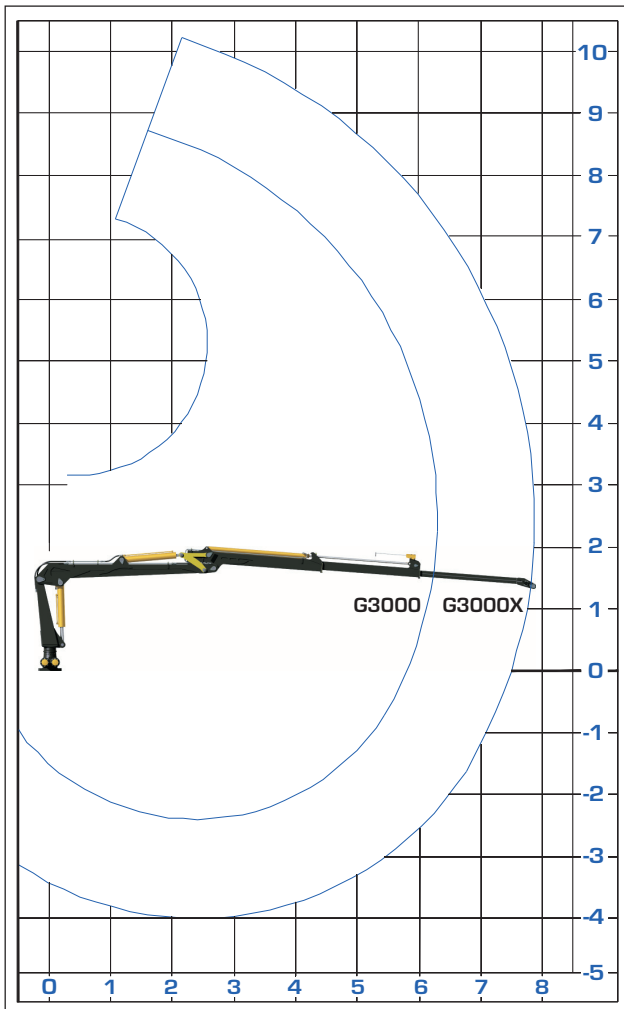

COSTA



Load diagram

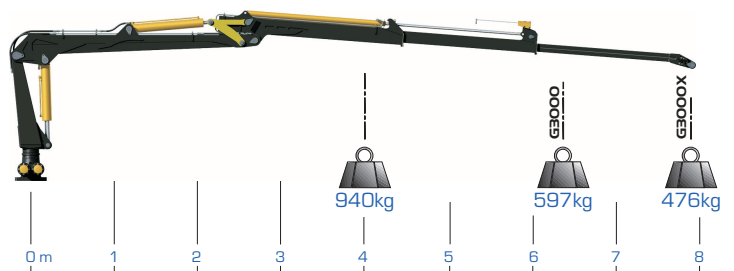

TECHNICAL SPECIFICATIONS

		G3000	G3000X
Load capacity	Ton.m	3.0	
Reach	m	6,3	7,9
Boom extension	mm	1,55	3,1
Slewing torque	kN.m	14,8	
Slewing angle	° (degrees)	400	
Height (slewing carter to column articulation)	mm	1490	
Width in tranport position	mm	1246	
Weight (without grapple, rotor or folding legs)	kg	845	898
Recomended Pump	Work pressure Oil flow Required power	bar l/min kW	180 60-80 20-27
Recomended equipment			
Rotor capacity	Ton	4,5	
Rotation angle		continuous	
Rotation torque	kN.m	1,2	
Weight	kg	27	
Grapple		COSTA G500	
Area	m2	0,22	
Weight	kg	125	



COSTA

Afonso O. Costa - Fábrica de Máquinas Agrícolas e Florestais, Lda

R. Poeta Cavador, Moita
3780 - 476 Anadia, PORTUGAL

Tel. (+351) 231 510120
Fax (+351) 231 510125

www.aocosta.pt
geral@aocosta.pt